

Reg. No. :

--	--	--	--	--	--	--	--	--	--	--	--	--	--	--	--	--	--	--	--	--

Question Paper Code : 60643

B.E./B.Tech. DEGREE EXAMINATION, NOVEMBER/DECEMBER 2016.

First Semester

Civil Engineering

GE 2111/ME 15 — ENGINEERING GRAPHICS

(Common to all branches)

(Regulations 2008)

Time : Three hours

Maximum : 100 marks

Answer ALL questions.

(5 × 20 = 100)

1. (a) The focus of a conic is 50 mm from the directrix. Draw the locus of a point 'P' moving in such a way that its distance from the directrix is equal to its distance from the focus. Name the curve. Draw a tangent to the curve at a point 60 mm from the directrix. (20)

Or

- (b) Draw the front view in the direction of X, top view and left hand side view of the given parts in Figure 1. (20)

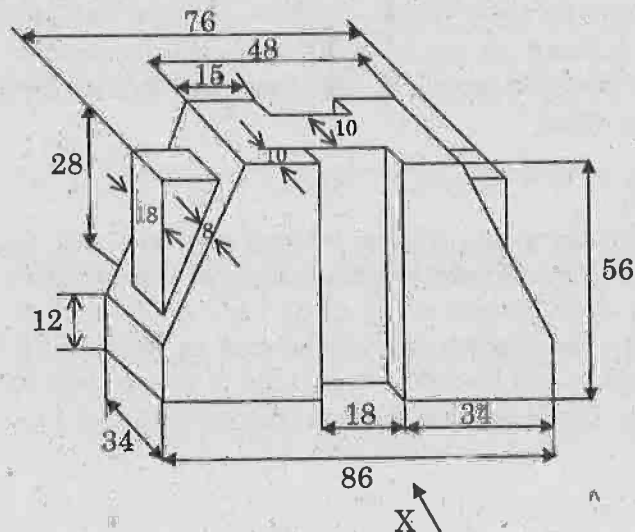

Figure 1.

2. (a) The top view of a line AD is 65 mm long is inclined at 30° to the reference line. One end A is 20 mm above HP and 10 mm in front of VP. The other end B is 60 mm above HP and is in front of VP. Draw the projections and find the true length of the line and its true inclinations to HP and VP. (20)

Or

- (b) A hexagonal lamina of 24 mm side has its surface inclined at 30° to HP. Its one side is parallel to HP and inclined at 45° to VP. Draw its projections by change of position method. (20)
3. (a) A pentagonal prism with side of base 30 mm and axis 60 mm long is resting with an edge of its base on HP, such that the rectangular face containing that edge is inclined at 60° to HP. Draw the projections of the prism when its axis is parallel to VP. (20)

Or

- (b) A pentagonal pyramid with side of base 30 mm and axis 60 mm long rests with an edge of its base on HP such that its axis is parallel to both HP and VP. Draw the projection of the solid. (20)
4. (a) A cylinder of base diameter 50 mm and height 60 mm rests with its base on HP. It is cut by a plane perpendicular to VP and inclined at 45° to HP. The cutting plane meets the axis at a distance 15 mm from the top base. Draw the sectional plan and the true shape of the section. (20)

Or

- (b) A hexagonal prism edge of base 20 mm and axis 50 mm long rests with its base on HP such that one of its rectangular faces is parallel to VP. It is cut by a plane perpendicular to VP, inclined at 45° to HP and passing through the right corner of the top face of the prism. Draw the sectional top view and develop the lateral surface of the truncated prism. (20)
5. (a) A right circular cone of base diameter 60 mm and height 75 mm is cut by a plane making an angle of 30° with the horizontal. The plane passes through the mid point of the axis. Draw the isometric view of the truncated solid. (20)

Or

- (b) A rectangular prism of base 50 mm \times 30 mm and height 50 mm lies on its base on the ground plane. A vertical edge touches the picture plane and one of the longer edges of its base is inclined at 45° to the PP and behind it. The station point is 50 mm in front of PP, 75 mm above the ground plane and lies in a central plane that passes through the center of the prism. Draw the perspective view of the prism. (20)